

JBC

www.jbctools.com

Product
website



INSTRUCTION MANUAL



AP250

Manual-Feed Soldering Iron

This manual corresponds to the following references:

AP250-B

Packing List

The following items are included:

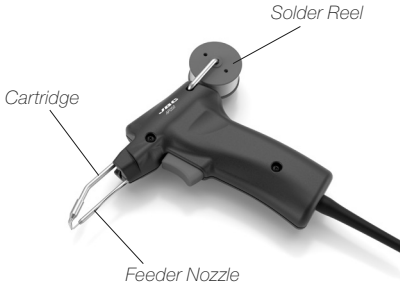

Manual-Feed Soldering Iron 1 unit

Already assembled in the soldering iron:

- Ref. 0019212 - **ø1 mm Feeder Nozzle**
- Ref. C250403 - **Cartridge**
- Ref. SN5450 - **Solder Reel**

ø1.5 mm Feeder Nozzle 1 unit

Ref. 0019211



Philips Screwdriver PH1x50 1 unit

Ref. 0031586



Cartridge Extractor Pliers 1 unit

Ref. PLR196



Reel 1 unit



Manual 1 unit

Ref. 0031412

Features and Connections

AP250 works with Modular control units such as DI, DDE or DME (APS stand is needed). As an alternative, Compact station CA includes AP250.

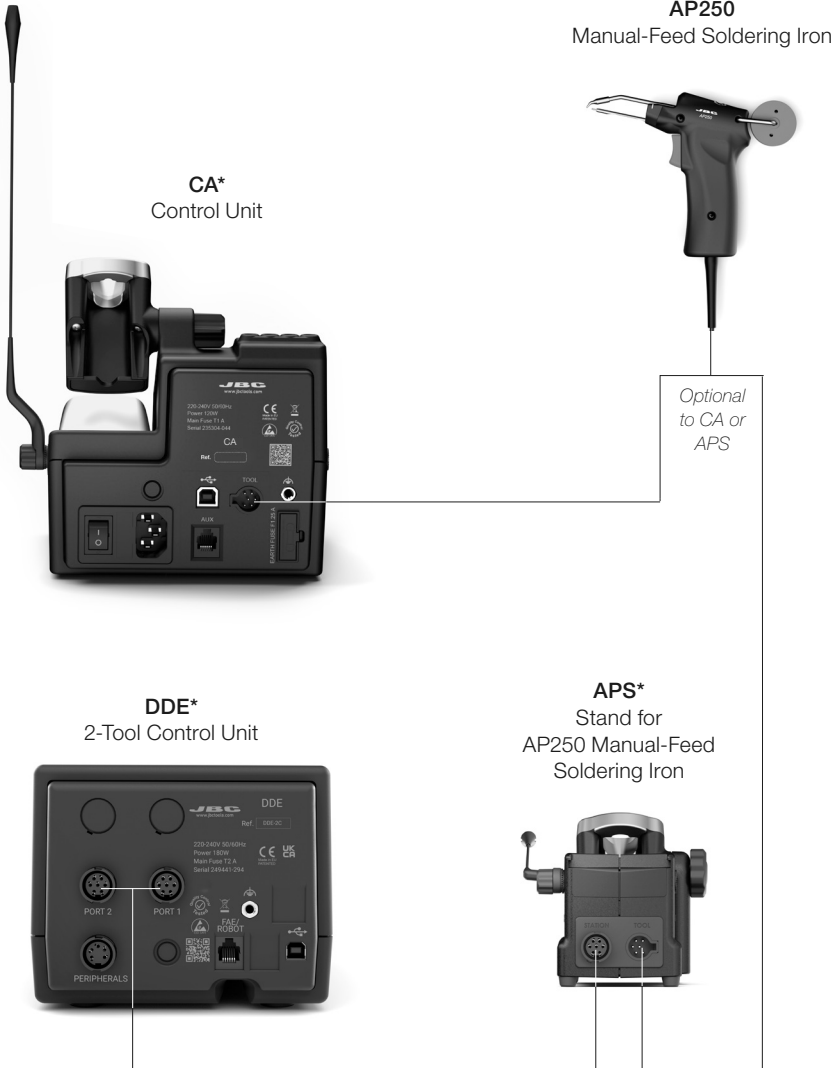

* Not included, sold separately.

Changing Cartridges

For a safe cartridge change, unplug the tool or turn the station off before following these guidelines:

1. Removing

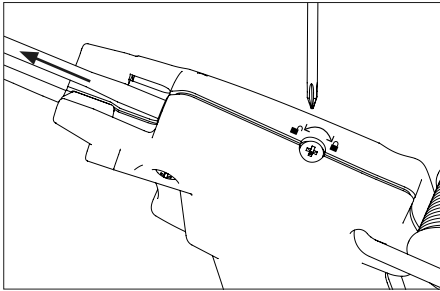

Loosen the screw and remove the cartridge. Use JBC's PLR196 cartridge extractor pliers to remove it if it is still hot.

2. Inserting

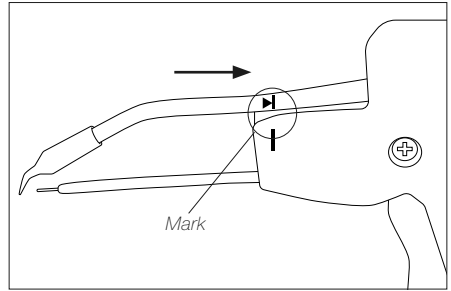

Important: Insert the cartridge up to the mark for a proper connection.

3. Aligning

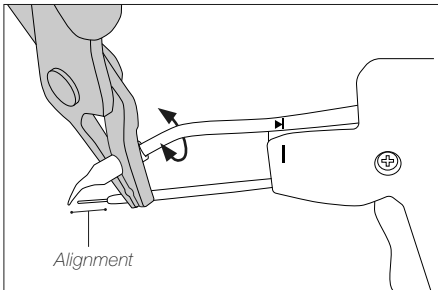

Align the tip of the cartridge with the feeder nozzle. Use JBC's PLR196 cartridge extractor pliers for a correct tip alignment.

4. Fixing

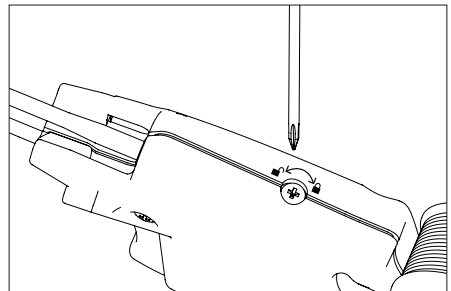

Important: Tighten the screw again. This is necessary for the tool to function.

Replacing the Solder Reel

1. Removing the Remaining Solder Wire

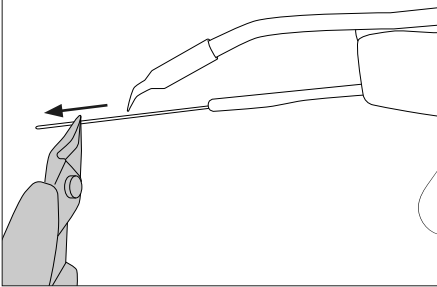

Pull out the remaining solder wire from inside the feeder nozzle. Use pliers if necessary.

2. Replacing the Solder Reel

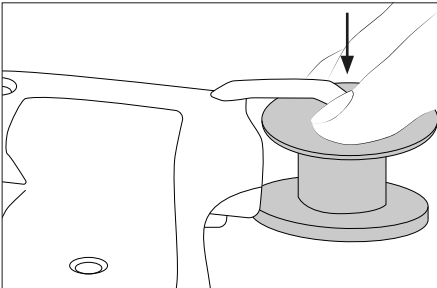

Remove the empty reel as shown and fit the new one in the same direction.

3. Inserting the New Solder Wire

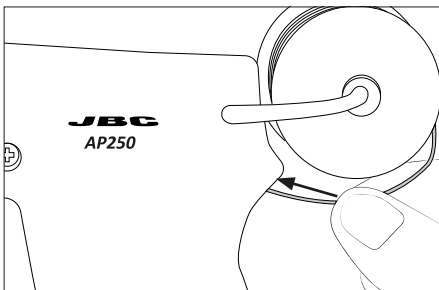

Insert the solder wire while pushing the trigger repeatedly until the solder wire comes out of the nozzle.

Note: Use solder wire $\varnothing 0.8 - 1.0$ mm with nozzle ref. 0019212 and $\varnothing 1.1 - 1.5$ mm with ref. 0019211

Changing the Feeder Nozzle

 Make sure the tool is unplugged.

1. Remove the Reel

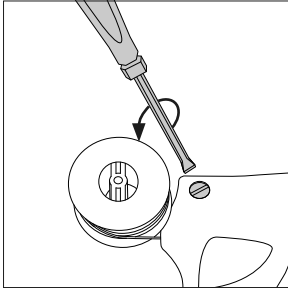

Loosen and remove the back side screw to remove the reel and to take out the solder wire from the nozzle.

2. Remove the Cover

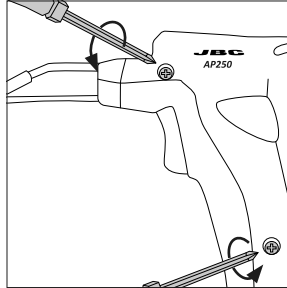

Then remove the two front side screws and lift off the cover.

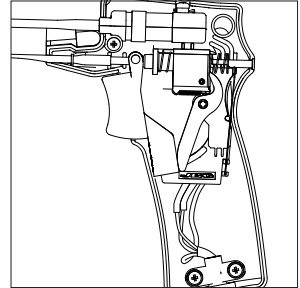

3. Remove the Nozzle

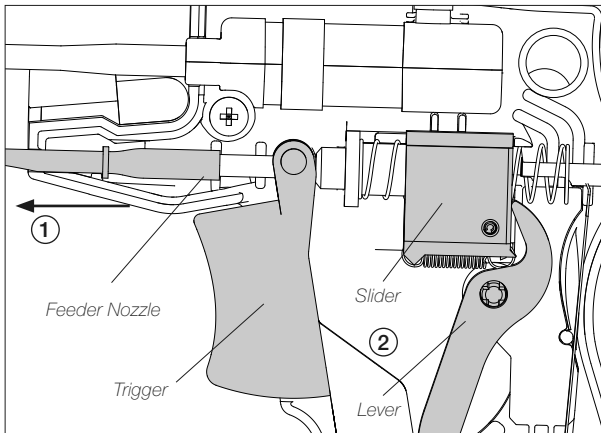

Take out the feeder nozzle and replace it with the new one (1) **while holding the following three highlighted components in place (2):** the trigger, the lever and the slider.

Reassemble the housing and tighten the 3 locking screws.

Important: Do not disassemble the slider, the trigger or the lever. It is imperative to hold them in its place (2).

Regulating the Feeder Nozzle

Depending on the components that are being soldered or on the cartridge being used, the length of the feeder nozzle can be either shortened or lengthened (max 10 mm / 0.394 in).

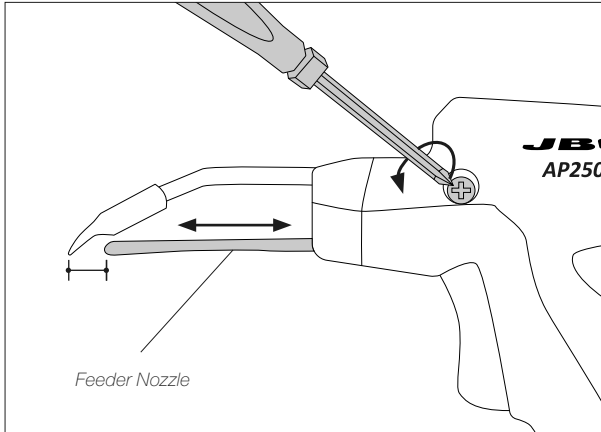

Loosen the screw (1) to change the length of the feeder nozzle (2).

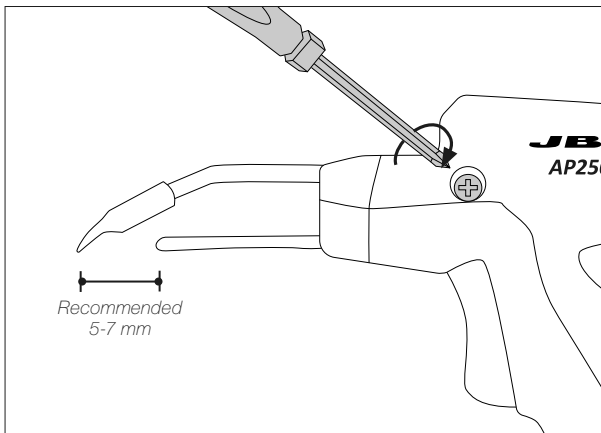

Adjust the feeder nozzle to the recommended length (5-7 mm / 0.19-0.27 in) and tighten the screw.

Compatible Cartridges*

AP250 Manual-Feed Soldering Iron works with C250 cartridges. Find the model that best suits your soldering needs on www.jbctools.com.

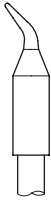

Conical Bent

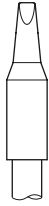

Chisel



Chisel Bent



Bevel

Accessories

Solder Reel Stand*

For production line work, BES Solder Reel Stand is the ideal solution for easy solder wire supply. Suitable for solder reels up to 2.5 kg / 5.512 lb.

Wrap the solder wire twice around the empty reel as shown and then guide it into AP250.

BES*
Solder Reel Stand



*Wrap
solder wire
twice*



AP250
Manual-Feed Soldering Iron

** Not included, sold separately.*

Accessories

Fume Extractor Accessory*

The fume extractor accessory is an easy and safe solution for extracting the fumes generated at the solder joint while soldering.

If you already have a high pressure suction system (filter required) on your workbench, you can connect it to AP250 by means of the fume extractor accessory for occasional fume extraction.

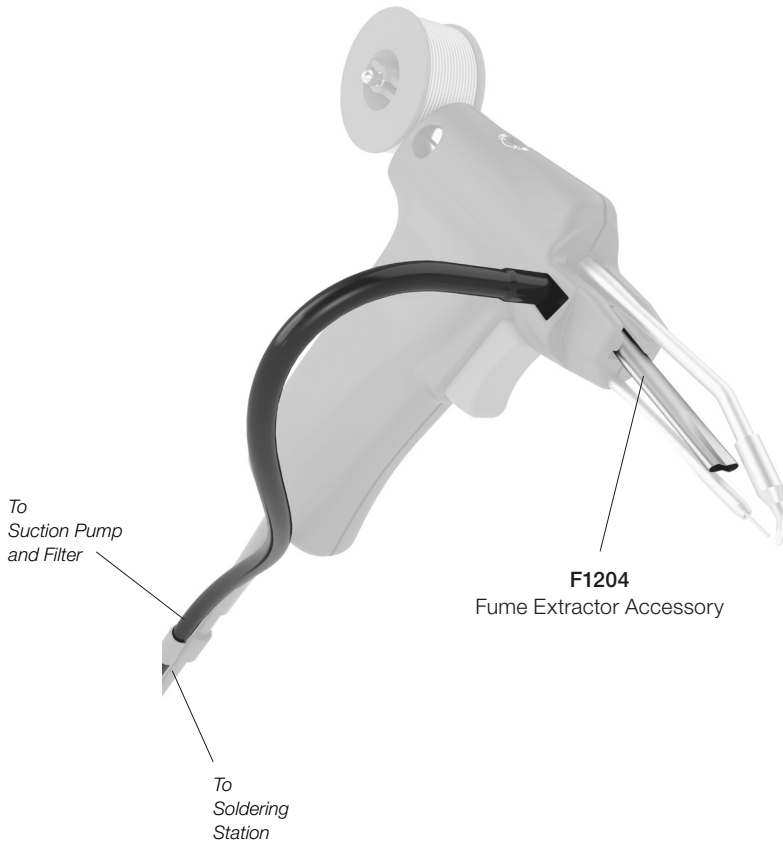

** Not included, sold separately.*

Specifications

AP250

Manual-Feed Soldering Iron

Ref. **AP250-B**

- Solder Wire Diameter:	Up to 1.5 mm / 0.06 in
- Total Net Weight:	232 g / 0.51 lb
- Package Dimensions / Weight: (L x W x H)	245 x 185 x 45 mm / 367 g 9.65 x 7.28 x 1.77 in / 0.81 lb

Complies with CE standards.
ESD safe.

JBC

Warranty

JBC's 2 year warranty covers this equipment against all manufacturing defects, including the replacement of defective parts and labor.

Warranty does not cover product wear or misuse.

In order for the warranty to be valid, equipment must be returned, postage paid, to the dealer where it was purchased.



This product should not be thrown in the garbage.

In accordance with the European directive 2012/19/EU, electronic equipment at the end of its life must be collected and returned to an authorized recycling facility.

